



Instruction Manual BS EN 1004-2:2021
The ALTO HD Side Cantilever Towers are certified to BS 1139-6:2022

3T - Through The Trapdoor Method

Assembly guide using **4 Rung** Starter Frames



Introduction

Please read these instructions carefully and ensure that you fully understand all of the information contained herein. All of the information in this document is vital for the safe utilisation of your Alto Heavy Duty Tower in Side Cantilever Tower applications.

These instructions only cover the assembly of this configuration of equipment, which is designed primarily for construction and maintenance tasks where access is required to one side of a standard tower footprint at platform heights of between 4m and 12m. All Alto Access products are professional quality engineered equipment designed primarily with safety in mind and meet or exceed all standards, recommendations and guidelines. Used properly, Alto access equipment will keep you safe when working at height.

This manual contains all of the information necessary to correctly assemble your Alto Heavy Duty mobile access tower equipment for this application in accordance with BS 1139-6:2022 and incorporates all of the requirements of the PASMA 3T method of assembly as endorsed by the HSE.

This manual should be used in conjunction with your Risk Assessment and Method Statement and in line with the Work at Height Regulations 2005 which place an obligation on employers to eliminate or minimise risks. This manual must be made available to the user/assembler at all pertinent times.

A Risk Assessment and Method Statement must be undertaken before installation commences and should include the relevant stabilisation to be applied to the specific structure being built in line with the guidance contained in this manual.

Only competent and qualified personnel should undertake erection, dismantling or alteration, organisation, planning or supervision of mobile access towers. In the case of any doubt, sufficient relevant additional training must be given beforehand to ensure safe use. For further information on the use of mobile access towers consult PASMA (www.pasma.co.uk; Tel +44 (0) 345 2 30 4041).

For any additional technical information or specific advice please contact the manufacturer Lakeside Industries Limited Tel: +44 1527 500577 or Email: sales@altoaccess.com.

Certifications

The Alto Heavy Duty Tower is a mobile access tower certified to BS EN 1004-1:2020 Class 3. These instructions cover applications outside the scope of BS EN 1004-1:2020, within the scope of BS 1139-6:2022 to ensure that the configuration of the equipment meets the relevant requirements. This tower is manufactured in our ISO 9001 accredited facility. This manual complies with BS EN 1004-2:2021.

Maximum Safe Working Loads

The safe working load of the tower is 2,500 kg including its own weight. The maximum leg load imposed by the tower on its supporting surface is 625 kg when loaded to its maximum safe working load. The tower is a Class 2 tower.

The maximum safe working load of any individual non-working platform within the main tower is 324 kg evenly distributed. The maximum safe working load of any cantilever platform is 170 kg.

The maximum safe uniformly distributed working load which may be placed on the working platform of the tower is 170 kg on the cantilever section and 324 kg on platform units within the main body of the tower.

The maximum number of working platforms allowed in this configuration is 1.

The maximum number of operatives permitted on the tower during use is 1.

The maximum number of operatives permitted on the tower during assembly and dismantling is 2.

The maximum number of operatives permitted on any one platform unit within the main tower is 1.

The maximum number of persons allowed on a cantilever platform at any one time either during assembly/dismantling or during use is one.

The maximum number of people on a working platform level permitted to simultaneously exert a horizontal load of 0.3 kN is 1.

If higher loadings are required, contact your supplier or the manufacturer - Lakeside Industries Limited, for advice. Tel: +44 1527 500577 or Email: sales@altoaccess.com.

Inspection Care & Maintenance

Alto Access equipment is designed and manufactured to the highest standards in the industry and is stronger, more robust and safer than any comparable competitor product. Properly cared for, it will give a long and productive service life.

Inspection and maintenance guidance is published by the manufacturer for Alto HD equipment. This may be found here: www.altoaccess.com/assets/inspection_hd.pdf

ALTO HD Tower System equipment should not be modified in any way and should only be repaired by the manufacturer - Lakeside Industries Ltd - or by authorised agents. If it is suspected that equipment has been damaged, modified or repaired by any other provider, the equipment should be quarantined and returned to Lakeside Industries Ltd for free inspection. No liability will be accepted in relation to

equipment that has been subjected to unauthorised modification or repair.

ALTO HD Tower System equipment is a robust product designed to operate in the construction industry environment. However, misuse or mishandling (including dropping or overloading or otherwise incorrectly using components) risks impairing the structural integrity of the components.

Components should be handled with care and stacked and secured safely whilst in transit.

Never use any equipment which is damaged, has parts missing or is improperly assembled.

Safety

- This information shall be available at the location of use of the prefabricated tower scaffold.
- This prefabricated tower scaffold shall only be used according to this information.
- A risk assessment and method statement must be prepared sufficient to ensure the safe assembly, use and dismantling of a cantilever tower structure and the elimination or minimisation of all consequent risks.
- All of the safety instructions contained in the Alto HD assembly manual supplied with your tower must be followed with the following supplementary requirements associated with cantilevers.
- Cantilevers may only be used with 3T Alto towers. Cantilevers may not be used with AGR towers.
- Cantilevers may only be used with double width towers. Cantilevers may not be used on single width towers.
- Never install cantilever equipment without having adopted and correctly installed one of the permitted stability solutions contained in the detailed instructions below. Never remove or alter any of the stability equipment whilst the cantilever is in place.
- Check that all of the necessary components, tools and equipment for the particular tower configuration to be built are on site, undamaged and functioning correctly. Damaged/incorrect components must not be used.
- BS 1139-6:2022 tower applications may only be used with 3T Alto towers. BS 1139-6:2022 tower applications may not be created using Advance Guard Rail (AGR) towers.
- Check that the surface on which the tower is to be located is capable of supporting the tower and its payload. Check that the level and slope of the ground do not render the location unsafe for the purposes of assembling, using and dismantling the tower.
- Beware obstructions when assembling, altering and dismantling the tower.
- When working outdoors, the weather forecast shall be taken into account before assembly, use and dismantling.
- The presence of a cantilever necessarily creates a different silhouette for wind effects and places

different loads on the tower structure when compared to a standard tower configuration. Accordingly, even greater vigilance is required to maintain the safety of any cantilever tower in windy conditions.

- Cantilever towers should be securely tied in to suitable adjacent structures at 4m intervals wherever possible to reduce risk.
- Platforms must be installed with vertical distances between them not exceeding 2.1m when assembling and dismantling.
- Towers must always be climbed from the inside using the built in ladders (or Alto stair units if applicable). If the work carried out from the tower requires frequent carrying of equipment and materials up or down the tower, an Alto stair tower should be used in preference to a ladderspan tower.
- The tower must be levelled when erected using the adjustable legs.
- Two or more persons are required for the safe erection and dismantling of this tower.
- Always comply with the Work at Height Regulations 2005 when erecting, dismantling & using the tower.
- When lifting components, tools or materials, always use reliable lifting equipment and fastening methods and always lift from within the footprint of the tower structure to prevent risk of the tower overturning.
- Users must be aware of the effects of horizontal and vertical loads on the structure when using the tower which may impair the stability of the tower. Examples would be loads resulting from work on an adjacent structure or wind loads which may be increased by tunnelling effects around adjacent buildings.
- Beware live electrical installations, cables, moving machinery or other obstructions when erecting, dismantling or using the tower. The tower is a conductive metallic structure.
- Do not use boxes, ladders or other items to gain additional height.
- Do not stand on guard rails for any reason.
- Never lean ladders or other equipment against the tower. Never climb the outside of the tower, with or without the cantilever structure attached.
- Never attach or use hoisting equipment on the cantilever platform unless prior approval has been obtained from the manufacturer.
- If the tower is to be used in connection with hoisting arrangements, this requires specific advice from the manufacturer to ensure safety. Contact the manufacturer Lakeside Industries Limited for advice on loadings Tel: +44 1527 500577 or Email: sales@altoaccess.com.
- Prefabricated tower scaffolds in accordance with this standard are not designed to be lifted or suspended.
- When fitting platforms always engage wind latches.
- Fit guard rails to all Platforms.
- Fit toe boards to all Working Platforms.

- Every erected tower must be inspected at least every seven days and any tower which has been left unattended should be inspected before use to ensure that:
 1. No components have been removed or relocated incorrectly;
 2. The tower is still vertical; and
 3. No environmental or other factors have arisen which will influence safe use of the tower.
 4. the applied stabilisation methods and devices are still correctly positioned and operating effectively.
- Alto Access Products recommends the use of the PASMA TowerSure inspection system. For more information, please visit: pasma.co.uk/towersure.
- This tower is not to be sheeted.
- Alterations to the prefabricated tower are only permitted where they are shown in these instructions.
- User training courses cannot be a substitute for instruction manuals and assembly, use and dismantling plans but can only complement them.
- Only the components specified in this information shall be used.
- Damaged or incorrect components shall not be used.
- Prefabricated tower scaffolds designed in accordance with this standard are not anchor points for personal fall arrest equipment.
- Working is only permitted on a platform with a complete side protection including guardrails and toeboards.
- In the event that an alteration to the prefabricated tower scaffold design is required, approval from the supplier and/or designer shall be obtained and a revised instruction manual or assembly, user and dismantling plan created.
- When a prefabricated scaffold tower is used as a means of access to another place it shall:
 - » Be built on base plates
 - » Be tied in to the adjacent structure with ties of sufficient number and capacity to cope with a horizontal load of 10% of the maximum UDL of the working platform i.e. 82 kg.
 - » Be positioned so that any horizontal gap between the platform of the prefabricated scaffold tower and the place being accessed is no greater than 25 mm; and
 - » Be positioned so that the upper surface of the platform and surface which is being accessed are vertically aligned within a tolerance of ± 25 mm.
 - » Means of protection shall be removed only for the time and to the extent necessary to gain access or egress or for the performance of a particular task and shall be replaced as soon as practicable.
 - » Attention is drawn to the Work at Height Regulations 2005 Schedule 1, Schedule 2 Regulation 5 and Schedule 3 Part 1 Regulation 5.
 - » Provision shall be made to prevent falls – not only from the prefabricated tower scaffold, but also

from the adjacent structure.

- » The safety of persons once they have transferred to the adjacent place shall be taken into account as this now becomes a place of work at height.
- » The strength of the adjacent place shall be assessed to verify that it is safe to step on to (e.g. not a fragile surface) and is a suitable and a safe place for work with adequate collective protection or other fall prevention measures.
- » A prefabricated tower scaffold shall not be used as an anchor point for personal fall protection or work positioning equipment. They are not designed for this purpose even when tied to a supporting structure.
- » A prefabricated tower scaffold shall not be used as a means or element of edge protection. They are not designed or suitable for this purpose even when tied to a supporting structure. Edge protection shall be designed and installed in accordance with BS EN 13374.

Wind Speeds

The weather forecast must be taken into account before assembly, use and dismantling. Persons using or responsible for towers must beware of the effect of wind on the structure. Cantilever towers present an additional risk in windy conditions and should not be erected if there is a significant risk of windy conditions.

Wherever possible, as a precaution, it is advisable to tie the tower in to a rigid structure if it is to be used where it is exposed to potential windy conditions. Users should beware the potential tunnelling effect of open ended or unclad buildings and narrow openings between buildings. We recommend that the use of the tower is discontinued in conditions where the wind speed is above 17mph (force 4).

WIND DESCRIPTION	BEAUFORT SCALE	AVERAGE SPEED	INFORMATION
Medium Breeze	4	13-17 mph	Safe to work on tower.
Strong Breeze	6	25-31 mph	Tie the tower to a solid structure. Do not work on tower.
Gale Force	8	39-46 mph	Towers must be dismantled. Towers must not be assembled.

Erecting & Dismantling the Tower

All BS 1139-6:2022 tower structures using Alto HD equipment must be built and dismantled in accordance with the step by step instructions set out below and having regard to the working at height regulations and Health & Safety legislation.

3T Method Explained

The “3T” or “through the trapdoor” method is one of the two permitted ways of assembling a tower without the assembler being at risk of falling. This tower is a 3T tower.

Step 1:

As each new level of platform is installed, the operative takes up a working position in the trap door of the platform, standing on the ladder and leaning back against the edge of the trapdoor aperture.

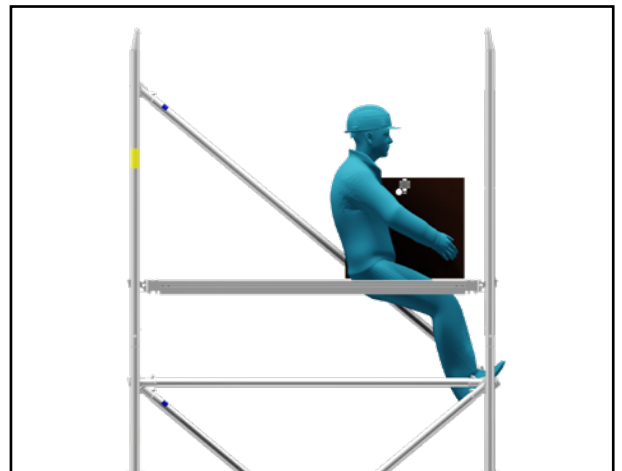

Step 2:

From this position the operative fits the horizontal braces 500mm and 1000 mm above the platform level (i.e. on the first and second available rungs). If the far end of the guardrail braces don't fully engage when they are put in place, the operative fully engages it when first climbing up onto the platform. This process ensures that operatives never have to stand on an unguarded platform.

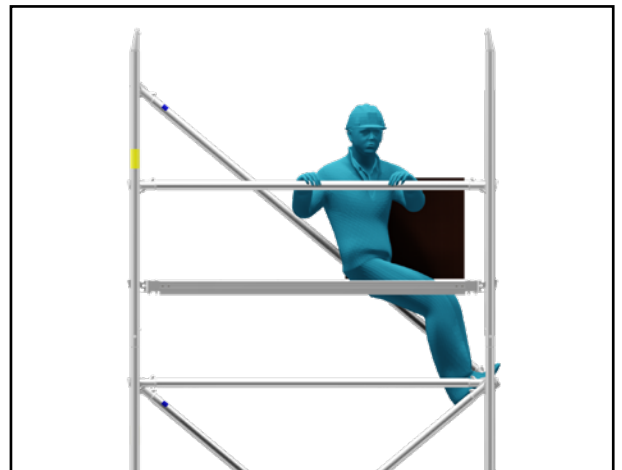

Frames

Frames **must** always be assembled with the offset conical head fitting pointing inwards towards the centre of the tower.



Braces

All braces are fitted with spring loaded pins that automatically lock the brace into position when attached to a tower. Brace hooks **must** be located either over the rung screw heads, between 2 screw heads or between the frame upright and a screw head to prevent lateral movement.

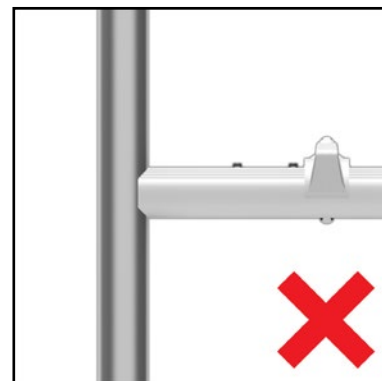
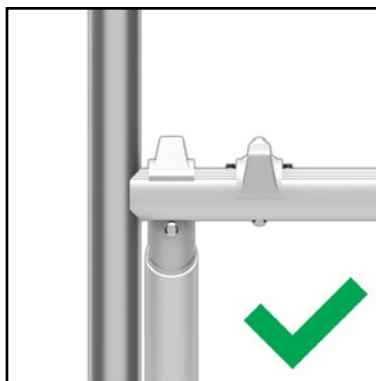

Diagonal braces **must** always be located with the claw opening facing down. Horizontal braces must be located with the claw facing either down (on the rung) or outwards (if on the upright).

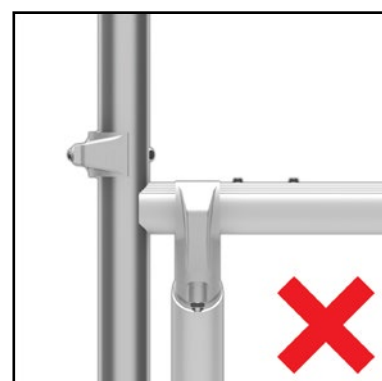
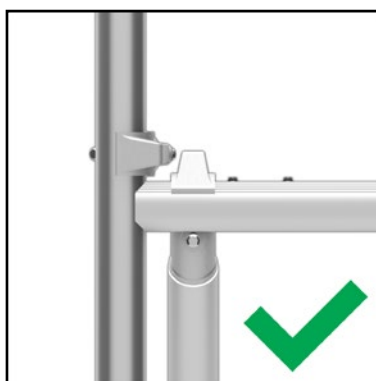

Moving the Tower

Before moving the tower, its overall height should be reduced to 4m working platform height or less. No persons, tools, equipment or materials shall be permitted to remain on the tower when it is being moved. Cantilever elements must be completely removed before moving the tower. The tower should only be moved by manually pushing it by the lowest frames at no more than walking speed. The tower must be kept vertical whilst being moved.

When moving the tower users are to be particularly careful of the following:

- obstructions, moving machinery or electrical cables and equipment, any overhead obstacles
- not to move the tower in wind speeds of 18mph (force 5) or above
- the effect of rough, uneven or sloping ground on the stability of the tower
- locking and unlocking the castors using the brake lever on the castor wheel to allow and prevent the tower moving at appropriate times
- towers may only be moved on flat and solid ground without obstacles having a maximum slope of 3%

After completing the movement:

- use a spirit level to ensure that the tower is vertical, using the adjustable legs as necessary
- ensure that the tower is safely supported on an appropriate surface

- check that the tower is correct and complete
- check that no environmental changes affect safe use of the mobile access tower
- check that stabiliser, ballast or other stability solutions are correctly deployed as per the manual

Unattended Towers

To prevent use by unauthorised persons of complete or incomplete towers when unattended, steps should be taken to prevent unauthorised access. Appropriate steps may include some or all of the following:

- Use of scaffold alarms.
- Suitable physical means such as barriers or site fencing to prevent access to the area immediately around the tower.
- Warning signs identifying the areas where access is not permitted should be displayed at the access points to area occupied by the tower.
- Attaching a well designed and correctly fitted ladder guard to the lowest levels of the tower.
- Appropriate site security.
- Towers which have been left unattended should be inspected before use as outlined on page 5 above.

Signage

After assembly or alteration, the following minimum information shall be displayed on the prefabricated tower scaffold and be clearly visible from the ground (e.g. on a tag):

- The name and contact details of the responsible person.
- If the tower is ready for application or not.
- The load class and the uniformly distributed load.
- If the prefabricated tower scaffold is intended for indoors use only.
- The date of assembly.
- The maximum number of simultaneous working platforms permitted.
- The maximum number of persons permitted on the working platform(s) during use.
- The maximum number of persons permitted on the tower during assembly and dismantling.
- The maximum number of persons permitted on any one platform.
- The maximum number of persons permitted on the cantilever platform.
- The maximum safe working load on working platforms.
- The maximum safe working load on the prefabricated tower scaffold.

- The load class of the prefabricated tower scaffold.
- The maximum horizontal force permitted at the working platform(s).
- The maximum wind limits for working on the prefabricated tower scaffold.
- The maximum wind limits for the prefabricated tower scaffold.

Component Schedule

The table below shows the additional components that are required **over and above the standard components stated in the relevant ALTO HD Tower Assembly Guide.**

CODE	PART DESCRIPTION	Wt	Tower tied in to structure		Buttress stabilisation	
			1.8m	2.7m	1.8m	2.7m
2238	150mm Dia. Castor Wheel	3.0			2	2
2240	HD Adj. Alum. Leg (silver collar)	1.3			2	2
2073	HD Access Bracket	5.5	2	2	2	2
2002	HD 1.4m Main Frame	10.9			2	2
2040	HD 1.8m Brace	2.6	2		4	
2041	HD 2.7m Brace	3.6		2		4
2080	HD 1.8 x 3 Rung Brace (Blue)	3.3			1	
2083	HD 2.7 x 3 Rung Brace (Black)	4.1				1
2043	HD 1.8m Platform	14.4	1		3	
2044	HD 2.7m Platform	20.4		1		3
2075	HD 1.8m Platform Infill plate	5.3	1		1	
2077	HD 2.7m Platform Infill plate	8.2		1		1
2069	HD 1.8m Timber Toeboard Side	7.3	2		2	
2070	HD 2.7m Timber Toeboard Side	11.3		2		2
2071	HD D/W Timber Toeboard End	5.2	2	2	2	2
2072	HD Side Cantilever Timber Toeboard End	3.2	2	2	2	2
2074	Timber Toeboard Corner Bracket	0.9	4	4	4	4
2079	Timber Toeboard In-line Bracket	0.8	2	2	2	2
SC-001	Swivel Couplers	1.1			4	4
	Calibrated solid ballast for:					
	Platform height up to 4.2m				375 kg	375 kg
	Platform height up to 6.2m				550 kg	550 kg
	Platform height above 6.2m				Tied-in only	Tied-in only

ASSEMBLY INSTRUCTIONS

Build the tower to the required working platform height following the relevant Alto HD assembly guide but do not fit the toe board unit as described in the instructions.

Determine which of the allowable methods of stability enhancement is to be adopted. Method 2 requires the 2 stabilisers on the opposite side to where the cantilever is to be installed to be left off until method 2 is complete.

Method 1 - Tying In to a structure

If the tower is to be tied in, the following information is relevant:

This prefabricated tower scaffold has been designed to be properly secured to a suitable adjacent supporting structure capable of withstanding the forces that will be imposed upon it by the attachment of the tower. Devices for securing the tower must be simultaneously rigid in both tension and compression and capable of withstanding and transmitting the loads imposed by the tower to the supporting structure.

Tie the tower structure into an adjacent rigid structure every 4m using tube and fittings connected to frame uprights. This is the safest method of stabilising a side cantilever tower and must be used for all side cantilever towers with a platform height of greater than 8.2m.

When used, anchors into concrete and masonry must be selected and installed in accordance with BS 8539.

AN EXAMPLE TYING IN ARRANGEMENT USING MASONRY ANCHORS



Ties should be located close to a node. A node is where a frame upright, rung, horizontal and diagonal brace meet.

Scaffold couplers and tubes used for tying in must comply with BS EN 74-1:2005 and BS EN 12811-2:2004 respectively.

All HD towers that are tied into an adjacent rigid structure should be able to withstand all but the most extreme UK weather conditions.

Braces and guardrails have been omitted for clarity only.

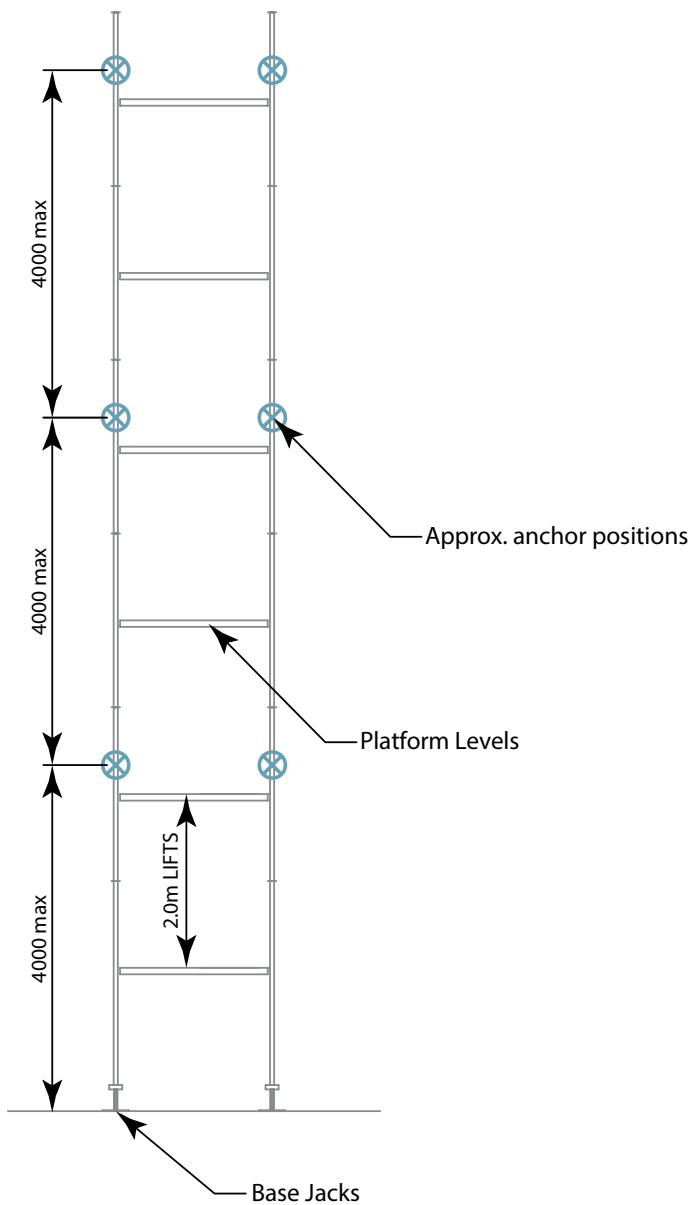

For more information on tying in, see separate guidance documentation issued by the manufacturer.

Method 2 - Buttress Stabilisation

(may be used for platforms up to a working height of 8.2m only)

Step 1

Attach two 4 Rung Main Frames to the main structure on the opposite side to the planned cantilever, using two swivel couplers on each frame. Ensure that the frames have leg & castor assemblies fully installed in the outer legs only with the brakes fully engaged. Make sure that the frame head fittings are pointing inwards into the tower.



Step 2

Connect a horizontal brace to the bottom rung of the frames as close to the outer frame upright as possible.



Step 3

Connect a diagonal brace (blue brace for the 1.8m platform tower or a black brace for the 2.7m platform tower) to the frames as shown. Keep the diagonal brace as close to the frame uprights as possible.





Step 4

Connect a horizontal brace to the top rung of the frames. Position the brace as close to the outside of the tower as possible. Now install two plain platforms onto the bottom rung of the frames.



Step 5

Position the ballast across both platforms. Ensure a similar weight is on both platforms. Secure them to the tower (e.g.: using a padlock and chain) to prevent unauthorised removal. Ballast weights must be made of rigid materials such as steel or concrete. Liquids or granular materials may not be used. All ballast must be secured in position. See table on page 11 for correct weights.



Step 6

Connect 2 stabilisers to the outer corners of the two buttress frames. Fix the shorter arm to the lowest part of the frame, then connect the longer arm to the upper part, ensuring the foot is firmly placed on the ground. Small vertical adjustments can be made to either arm to guarantee a sturdy placement.

ASSEMBLY INSTRUCTIONS - All Platform Working Heights

Step 1

Working off the top of the tower, fit 2 access brackets to the uprights on the side of the tower where the cantilever is required, as shown. Ensure that each bracket is located with its spigot facing upwards and the rungs are in-line with the rungs on the main tower. **There should only be 1 diagonal brace at the top of the tower. This needs to be on the opposite side to the cantilever, as shown.**

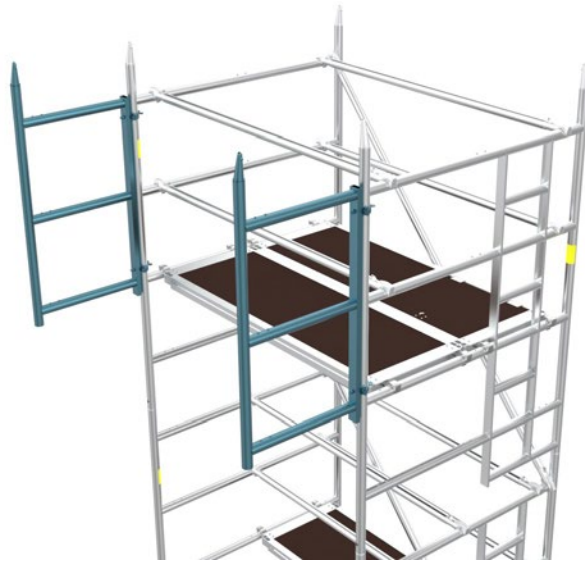

Step 2

Manoeuvre the brackets so that they are parallel to each other and at right angles to the sides of the working platforms. Ensure that the wing nuts on the bracket couplers are tightened so that it is not possible to move the side access bracket frame without loosening the wing nuts.

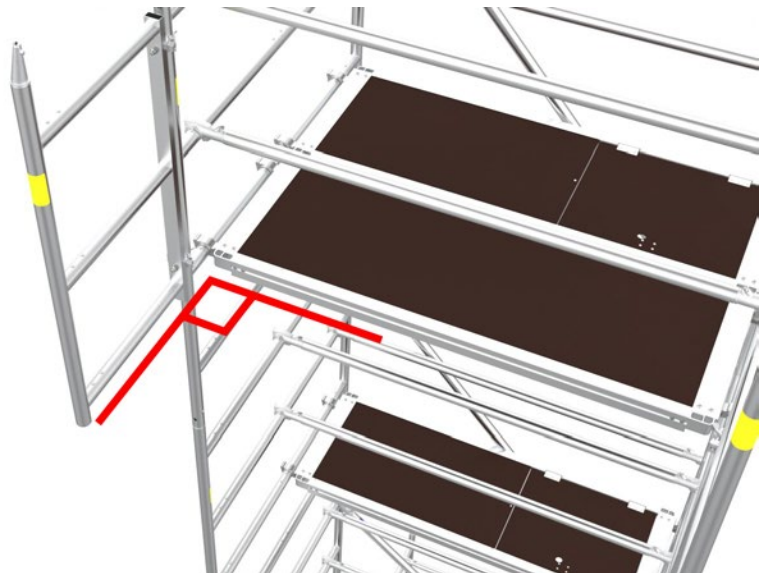

Step 3

Locate a plain platform onto the bottom rung of the access brackets. Now - still working from the main tower - engage the 2 wind latches on the underside of the platform on the cantilever.



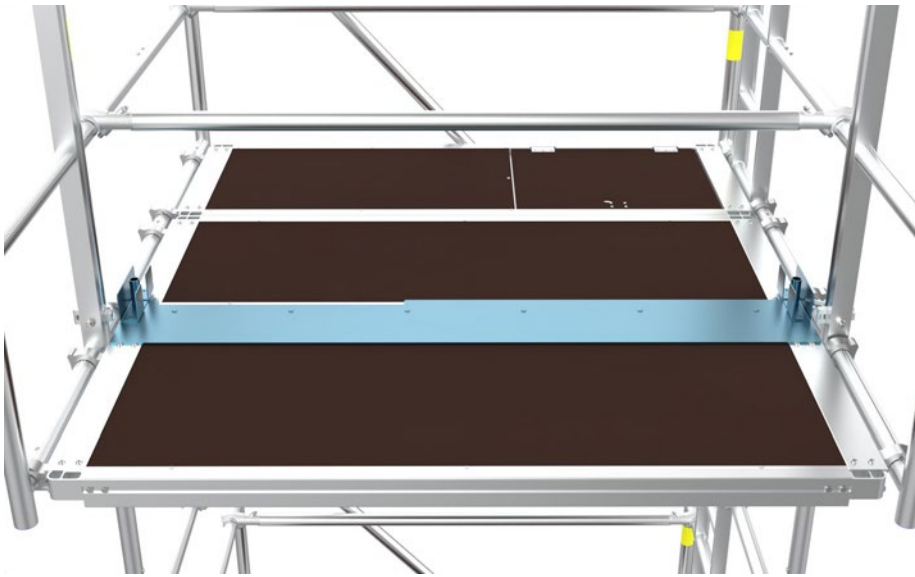

Step 4

Fit the platform infill plate between the main tower platform and the cantilever platform. Use the in-line toeboard brackets to connect the plate to the main tower platform. The dowel on the toeboard brackets locate through the hole in the infill plate, then down into the corners of the platform. Do not fit the brackets on the cantilever platform.

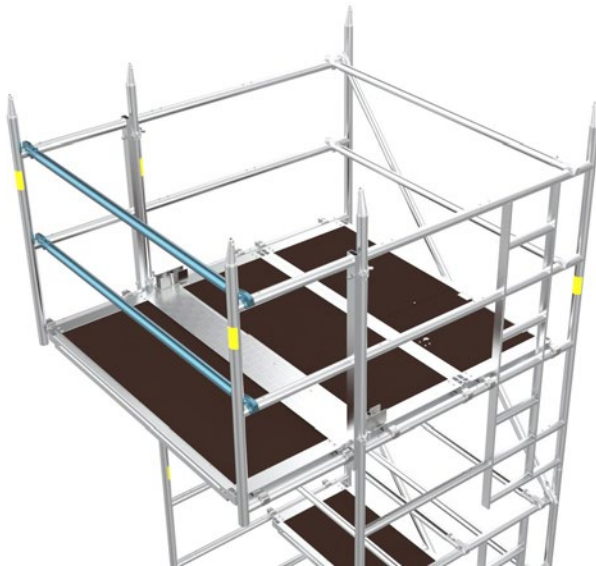

Step 5

Fit two additional horizontal braces to the 2 rungs of the access brackets - as close to the outside upright as possible - to form the new guard rails for the cantilever platform, as shown. Now, remove the two horizontal braces from tower (between the tower and cantilever) to allow access onto cantilever platform. Store the braces safely for the dismantling procedure.

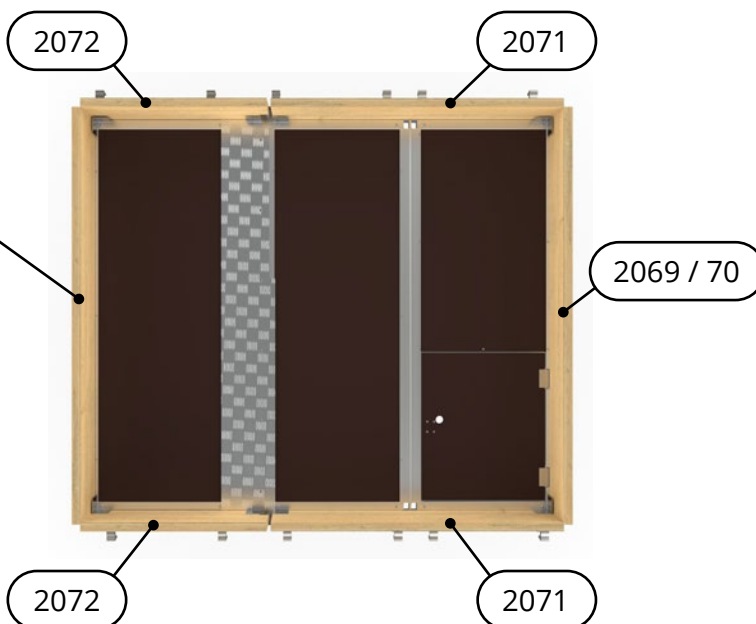

Step 6

Finally, install the remaining toeboard clips and wooden toeboard panels onto the working platform. Ensure that a notice stating "WARNING: THE MAXIMUM LOADING ON THE CANTILEVER IS 170 Kgs" is prominently displayed adjacent to the cantilever area and the appropriate signage detailed on page 10 is displayed at the base of the tower.

DISMANTLING INSTRUCTIONS - All Platform Working Heights

Step 1

The dismantling procedure requires a minimum of 2 operatives to complete the task safely.

To start, first remove the wooden toeboard sections and toeboard corner brackets. Leave the in-line toeboard brackets and the infill plate installed.

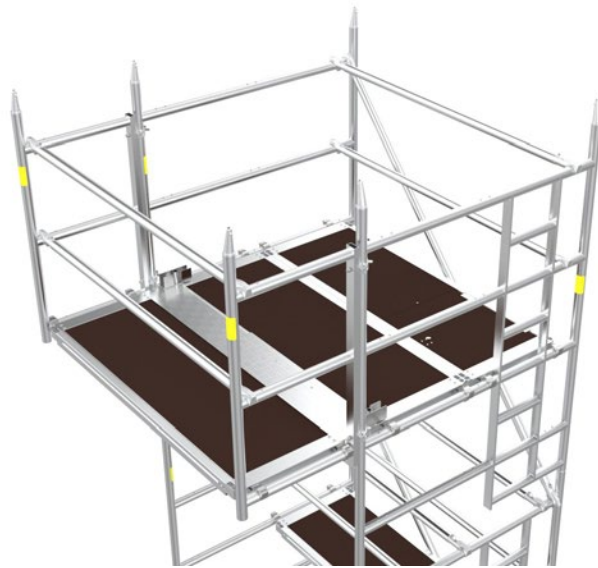

Step 2

Install the 2 spare guard rail braces to the main tower structure as shown. Ensure both ends are fully engaged.

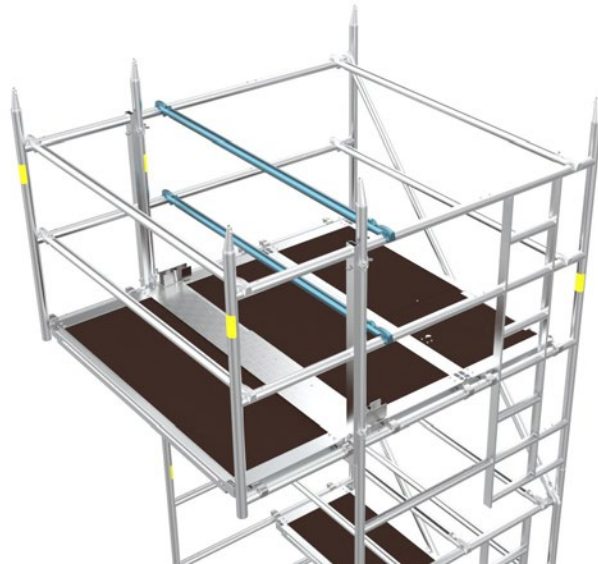

Step 3

Working from the newly guard railed main platform on the tower, remove the two horizontal guard rail braces from the far side of the access brackets.

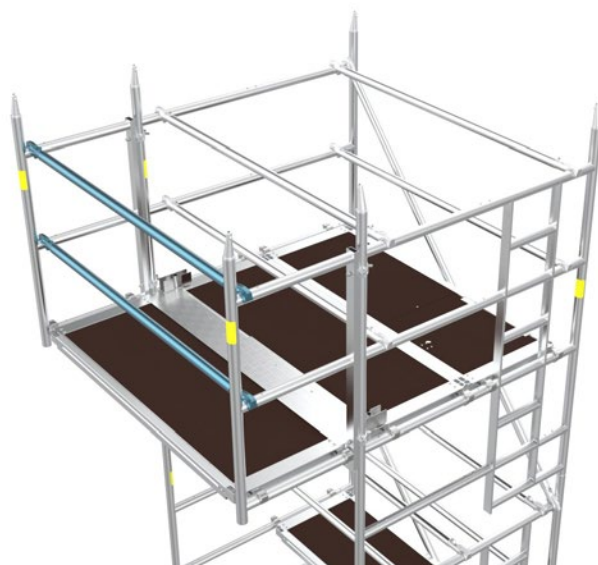

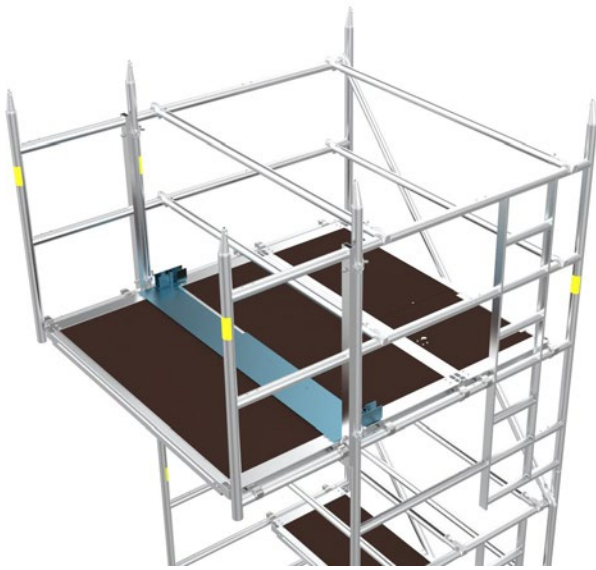

Step 4

Remove the in-line toeboard brackets and the infill plate between the tower platform and the cantilever platform.



Step 5

Remove the cantilever platform from the access brackets. Then disconnect and remove the access brackets off the tower.



Step 6

At this stage, the stability enhancement fitted prior to the installation of the cantilever itself may be removed – or it can be left to a more convenient stage in the dismantling of the tower.

Continue dismantling the tower as per the instructions in the assembly guide.

Components

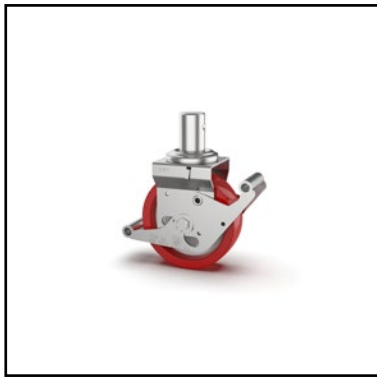

2238 150mm castor wheel



2240 HD Adj. Leg



2002 HD 1.4m Main Frame



2073 HD Access Bracket



2040 1.8m Brace



2041 2.7m Brace



2080 1.8m x 3 Rung Brace
(Blue)



2083 2.7m x 3 Rung Brace
(Black)

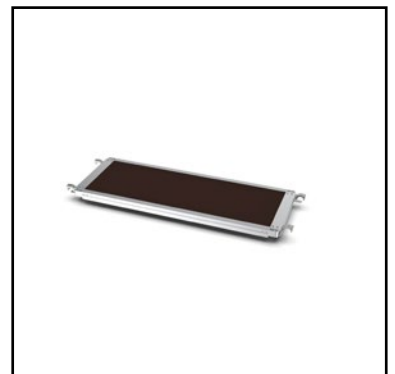

2043 1.8m Plain Platform



2044 2.7m Plain Platform

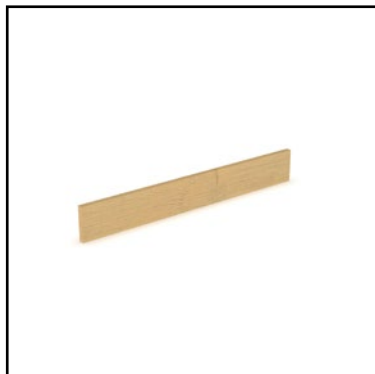

2069 HD 1.8m Timber Toeboard
Side



2070 HD 2.7m Timber Toeboard
Side



2071 HD D/W Timber Toeboard End

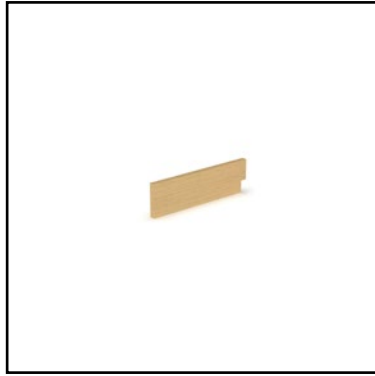

2072 HD Side Cantilever Timber Toeboard End



2074 HD Timber Toeboard Corner Bracket



2079 HD Timber Toeboard In-line Bracket



2075 1.8m Platform Infill Plate



2077 2.7m Platform Infill Plate



SC-001 Swivel Couplers

THE HEIGHT OF SAFETY

For more information regarding our range of access products and services, please get in touch with us:

Lakeside Industries Ltd

Unit 19 Howard Road, Park Farm Industrial Estate
Redditch, Worcestershire. B98 7SE. UK

t: +44(0)1527 500 577

e: sales@altoaccess.com

w: www.altoaccess.com



@lakesideindust



@altotowers



lakeside-industries-ltd



ISO 9001:2015
Management
System



www.tuv.com
ID 9108630741



ASSOCIATE MEMBER



Manufacturing Member

Lakeside Industries Ltd

Unit 19 Howard Road, Park Farm Industrial Estate, Redditch, Worcestershire. B98 7SE
+44(0)1527 500577 | sales@altoaccess.com | www.altoaccess.com



LAKESIDE
INDUSTRIES